

MAXxAIR II

Rain Covers for RV Roof Vents
Fresh Air Rain or Shine!

Tools Required:

DRILL WITH 3/16 DRILL BIT
PHILLIPS SCREW DRIVER
ADJUSTABLE WRENCH
PENCIL

INSTALLATION INSTRUCTIONS

① Based on your roof vent location, choose which side of the MaxxAir II to install the hinged brackets. Install as shown in Fig. 1 using the #10 □ 32 screws and locknuts provided.

② With the louvers facing the rear of the vehicle, slide the MaxxAir II with the installed hinged brackets up to the side of your roof vent. Center the brackets front to back on the vent side wall. Mark location of slots in bracket onto the roof vent side wall. Move MaxxAir II out of the way. Drill 3/16 □ holes at center of the marked slots. Attach brackets with the #8 □ 32 screw. Place fender washers, lock washers and nuts on the inside of the roof vent side wall.

③ Close MaxxAir II, mark location of feet onto the roof on the opposite side.

④ Line brackets up with marks on the roof. Drill 3/16 □ holes in the side wall of the roof vent at the center of each slot location. Attach brackets to the vent side wall with the #8 □ 32 screws. Place fender washers, lock washers and nuts on the inside of the roof vent side wall.

⑤ Close MaxxAir II and slide the two snap lock pins into place as shown. Press the snap lock pins downward to lock into position. Installation Complete

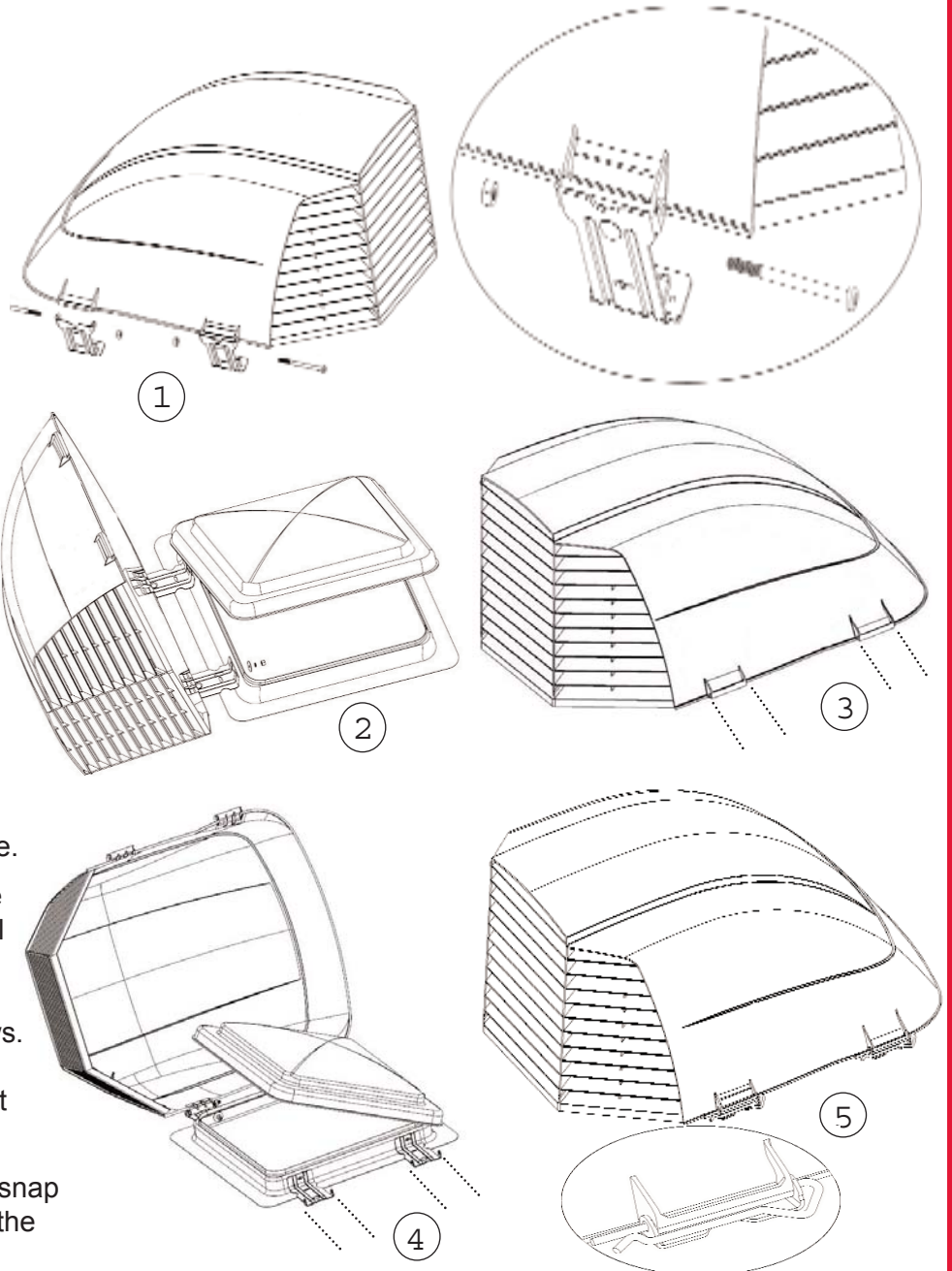

DID YOU KNOW:

- MaxxAir II has more open louver area, for more fresh air, than any other vent cover.
- Hinged hardware included provides easy opening for cleaning and inspection.
- Solid, sleek aerodynamic one-piece design
- Only vent cover with a 6 year warranty.

Contents of Kit

- 1 - MaxxAir II Vent Cover
- 4 - Aluminum Brackets
- 2 - Snap Lock Pins
- 2 - #10-32 x 2.75" SS Screws
- 2 - #10-32 SS Lock Nuts
- 4 - #8-32 x 1/2" SS Phil. HD Screws.
- 4 - #8-32 SS Nuts
- 4 - #8 SS Lock Washers
- 4 - #8 Fender Washers



Register Your MAXxAIR II Online

www.maxxair.com

Get the latest news from MaxxAir and be eligible to win our monthly prize drawing!