

For ELECTRIC TRAILER WINCH Models:

T10124-C Day Runner (cable)

T10125-Csw Salt Water Series Day Runner (cable)

Every installation can be different. If you have any questions or difficulty installing this product, TRAC is here to help!

First **READ THIS MANUAL.**

If you still need help, call us from 9 am to 4 pm

(central time) Monday – Friday.

(615) 641-2542

Trailer winches are used for launching and loading boats on trailers. Please read and save these instructions. Read carefully before attempting to install, operate or maintain the winch. Protect yourself and others by observing all safety information. Failure to comply with instructions could result in personal injury and/or property damage!

UNPACKING

When unpacking, inspect for any damage that may have occurred during transit. Make sure any loose bolts, nuts, etc. are tightened before putting unit into service.

SPECIFICATIONS

Various load conditions will affect winch performance. The line pull required for a specialized application depends on the weight of the load, condition of the trailer, and the incline of the loading ramp. The chart below is a guideline only.

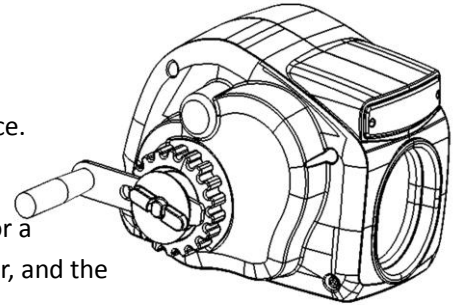

Model Name	Small Craft	Day Runner	Lite Cruiser (Cable)	Lite Cruiser (Strap)
Suggested Boat Length	Up to 18'	Up to 20'	Up to 24'	Up to 24'
Rolling Boat Weight	5,000 lbs.	7,000 lbs.	10,000 lbs.	10,000 lbs.
Line Speed	6 FPM	6 FPM	6 FPM	6 FPM
Pulling Capacity	2,000 lbs.	2,500 lbs.	3,500 lbs.	3,500 lbs.
Remote Control on 9' Cord	Yes	Yes	Yes	Yes
Wireless Remote Control	No	Yes	Yes	Yes
Power Requirement	12V	12V	12V	12V
Wiring Harness	Included	Included	Included	Included
Cable Length	30'	30'	30'	20' Strap
Circuit Breaker	Yes	Yes	Yes	Yes
Light	Yes	Yes	Yes	Yes
Limited Warranty	2 year	2 year	2 year	2 year
Unit Weight	16 lbs.	17 lbs.	24 lbs.	23 lbs.
Winch Dimension (LxWxH)	8.25" x 9" x 6.75"	8.25" x 9" x 6.75"	9.5" x 9.5" x 8"	9.5" x 9.5" x 8"
Model Number	T10121-C	T10124-C T10125-Csw	T10128-C T10130-Csw	T10129-S
UPC	666996101215	666996101246 666996101253	666996101284 666996101307	666996101291

GENERAL SAFETY INFORMATION - Throughout this manual potential safety hazards will be noted with the following terms. Please read and understand these terms before operating the product.

⚠ DANGER

Danger means a hazard that WILL cause death or serious injury if the warning is ignored.

⚠ WARNING

Warning means a hazard that COULD cause death or serious injury if the warning is ignored.

⚠ CAUTION

Caution means a hazard that MAY cause minor or moderate injury if the warning is ignored. It may also mean hazard that will only cause damage to property.

The Following Safety Precautions Must Be Followed At All Times

NOTE: Note means any additional information pertaining to the product or its proper usage.

The following safety precautions must be followed at all times:

1: Read all manuals included with this product carefully. Be thoroughly familiar with the controls and the proper use of the equipment. Only persons well acquainted with these rules of safe operation should be allowed to use the winch.

⚠ WARNING

Always unplug the wiring harness to prevent accidental starting before attempting to install, service, relocate or perform maintenance.

- 2. Never use the winch to lift or move people or animals.
- 3. Stand away from the winch when in use and keep children away from winch area at all times.

⚠ WARNING

Always stand clear of the area behind and between the load or anchor point and the winch. Serious injury could occur, if the cable breaks.

- 4. Always keep hands clear of cable spool (drum area).
- 5. Do not wear loose fitting clothing, scarves, or neck ties. Loose clothing may become caught in moving parts and result in serious personal injury.
- 6. Never use the winch for overhead lifting.
- 7. Always wire the winch with circuit breakers. Failure to use the breakers could cause overheating, thus creating a potential fire hazard or motor damage.

⚠ DANGER

Always leave a minimum of five wraps of cable on the drum at the bottom layer to achieve a rated load.

- 8. Inspect the cable for weak or worn condition, or kinking (short tight twist or curl) before each use.
- 9. When replacing the cable, always use a Trailer winch cable with the rating and cable strength.
- 10. Never substitute rope for cable. Possible injury could occur.
- 11. Do not attempt to pull a load greater than the rated load of the winch.
- 12. Do not use the winch to solely hold or support the boat. When the boat is on the trailer, secure the boat with tie-downs. Always use tie-down straps to hold the boat to the trailer. Damage could occur to the winch or the boat if boat-to-trailer tie-down straps are not used.
- 13. Never wrap the winch cable around the load. Use suitable chain to prevent the cable from kinking or fraying.
- 14. Always wear leather gloves when handling the cable. Steel cable can cause hand injuries.

⚠ CAUTION

After using the winch, always disconnect the power cord from the socket to avoid moisture collection in the socket and prevent the possibility of short circuiting.

- 15. Do not operate the winch under the influence of drugs, alcohol, or other medication.

⚠ WARNING

Do not use the winch to solely secure boat to trailer during transit. Use separate tie-down straps to secure the boat to the trailer.

Winch Installation

Install the electric winch in the same location as the existing hand winch. Remove the hand winch from the winch stand. Install the electric winch unit using three (3) 3/8" Grade 5 machine bolts, nuts and washers (included). If the winch stand does not have three holes, you may have to drill two holes for the two bolts which are located at the rear-end (end that has a printed label). Locate the three mounting bolts that came in the box. Remove the nut, and 2 washers from the bolts. Adjust retaining ring by unscrewing it to allow about 1/4 inch of space between the retaining ring and head of bolt. Insert head of bolt into keyhole on bottom of winch. Slide bolt head along the slot. Two bolts are to be located at the rear-end of the winch (below the label). Tighten retaining ring by threading the ring tight to the bottom of the winch. This will hold the bolts while you lower the winch onto the trailer's winch stand. Align the bolts with the bolt holes on the winch stand. Install flat washer, lock washer and nut.

NOTE: The cable (as it exits the winch) and the bow eye on the boat should be at the same height when the boat is in the fully loaded position on the trailer. If the bow eye is too high, extra stress is exerted on the boat's bow eye and stern. If the winch is too low, it will pull the boat into the bunks instead of along them. To achieve equal height of the winch and boat, raise or lower the winch stand. In most cases, the trailer manufacturer will have an adapter or optional winch stands. TRAC does not offer winch stands due to the great variety of trailers.

CAUTION

Eight (6) inches clearance is required between the winch and bow eye to prevent the cable hook from being drawn into the winch drum. If necessary, relocate winch stand or bow stop to obtain clearance.

To permanently wire your vehicle, refer to figure below and follow the outlined procedures.

1. Attach circuit breaker near positive (+) battery post.

CAUTION

Never attach circuit breaker to battery negative.

2. Run 8-gauge positive wire (not included) through or under the vehicle from battery to the rear of the vehicle. Attach wire at suitable intervals to the vehicle. Use nylon wire ties (not supplied) to secure the wire to the vehicle. Avoid sharp edges or places where the wire might rub or be cut.
3. Attach 8-gauge negative wire (ground wire) to the vehicle frame using bolt and lock nut. Before attaching the ground wire, clean metal with sandpaper. As an option the negative wire can be run (along with positive wire) to battery negative terminal.
4. At rear of vehicle, install a suitable (40 amp minimum) 12v socket, such as used for a trolling motor. Install the socket at rear of the vehicle and install plug at end of the winch battery cable.

Optional Wiring – An auxiliary battery may be used and can be installed on the trailer, or secured in the bed of a truck. If auxiliary battery is used, it should be a Marine deep-cycle battery.

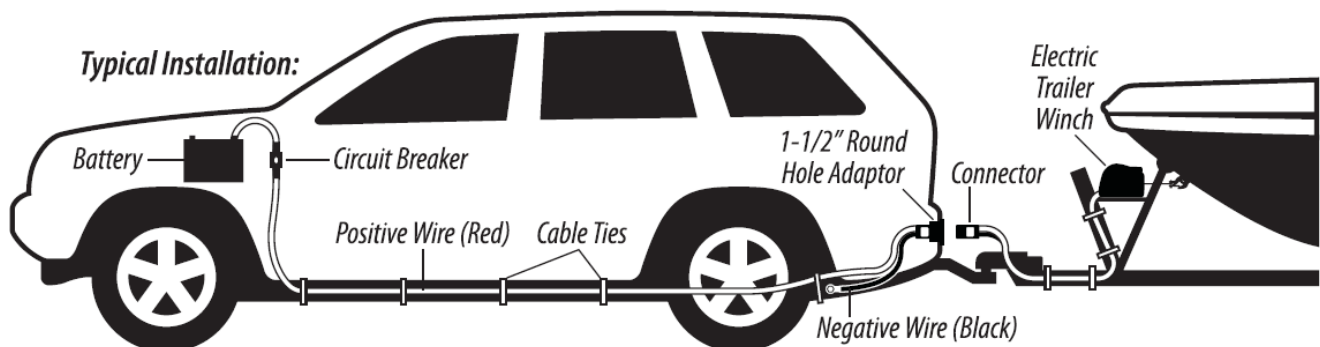

The winch comes with 9' of battery wire suitable to reach the rear of the tow vehicle or nearby battery. Vehicle Wiring Kit (item **T10135**) can be purchased separately. When the tow vehicle is running, its alternator/generator provides optimum voltage and current which will allow the winch to reach its maximum pulling power.

WIRED REMOTE

Winch comes with a **Wired** remote control - hand-held remote with 9' cord that plugs into the side of the winch.

Wireless Remote Control – Programmed at factory

This trailer winch is equipped to operate with a **wireless** remote control. Every wireless remote and winch are already programmed to communicate with each other. This is done at the factory, but you can also refer to the following instructions for a description of the remote functions and programming. If the wireless remote has a low battery or is lost, the wired remote may be used to release or retrieve the boat. If the remote battery is replaced or a new remote is used, it can be programmed using the following instructions.

PROGRAMMING THE WIRELESS REMOTE CONTROL

Wireless remote is preprogrammed at the factory to your winch. A new remote would need to be programmed.

To program the transmitter to the receiver:

1. Attach the battery power cord to the battery but do not plug power cord into winch.

2. Plug the wired controller into the winch.

3. Grasp the wired controller and while holding the "light-ON" button, plug the power cord into winch. Continue to hold "light-ON" button for a second, release.

4. Press and hold any button on the wireless remote. **Do not release the button.**

4. Remove power cord from winch.

5. **Continue** to hold wireless remote button for 10 seconds and release. Programming is complete.

6. Re-attach power cord.

WIRELESS REMOTE BATTERY REPLACEMENT

1. Remove the screw located on the back.

2. Separate the two halves of the transmitter; locate the battery and remove.

3. Replace battery with same type. Polarity is very important, make sure to place the negative end of the battery against the coil spring when replacing the battery.

WIRELESS REMOTE CONTROL FUNCTIONS

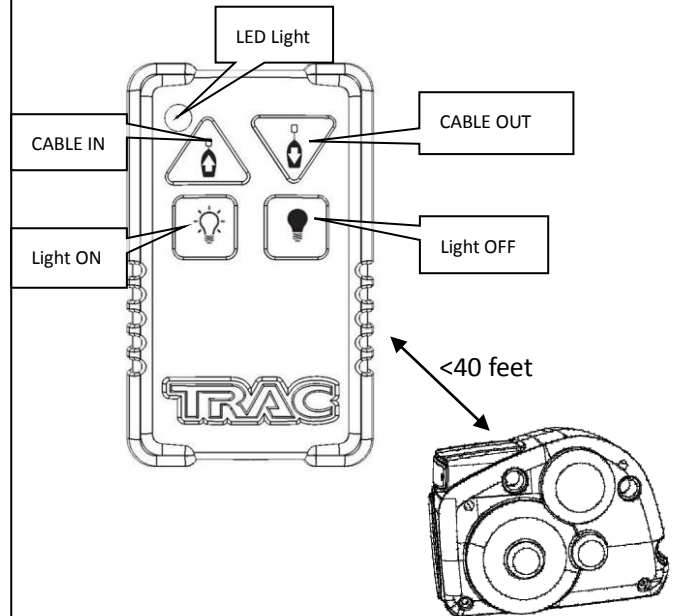

IMPORTANT

Use extreme caution when using this winch. Keep the remote dry. The battery may need to be replaced to ensure best performance. In the event that the remote is lost or broken another one can be obtained from TRAC for a nominal fee. The transmitter (remote) and receiver in the Trailer Winch comply with the FCC Part 15. Operation is subject to the following two conditions:

- I. This device may not cause harmful interference.
- II. This device must accept any interference received, including interference that may cause undesired operation.

RECOMMENDED OPERATING PROCEDURES

1. Always be sure the remote is operating with no obstructions between the remote and the winch, the signal may be blocked.
2. The remote performs best when it is within a 40 foot radius of the winch. Depending on the operating environment it is possible for the remote to perform well at a greater distance.
3. The winch receives a stronger signal when the remote is operated on one of the two sides of the winch. There exists a greater chance of the signal being interrupted if the remote is used in front of the winch. Never stand between the winch and the boat.

Winch Operation

UNLOADING

To unload the boat, follow these procedures.

⚠ WARNING

Clear the area around and behind the boat of people, animals, and obstructing objects before loading or unloading or personal injury could occur.

1. If it is not already attached, attach winch cable hook to the bow eye on the boat.

⚠ WARNING

Always stand clear of the area behind the boat and between the winch and boat. Serious injury could occur if the cable breaks. The clutch control knob on the side of the winch controls the free-spool function and is sometimes used to unload the boat or to pull cable out of the winch.

2. To free-spool and let cable out, loosen the wing nut and turn the clutch knob counterclockwise to release the clutch and allow the cable to free-wheel out.

3. Allow the boat to slide off the trailer (a slight push may be necessary to start the boat down the trailer). If needed, turn the clutch knob clockwise to use the brake to slow the boat at launch.

4. When the boat is in the water, release the winch cable hook from the bow eye. **Be sure to keep constant tension on the cable/strap when free spooling in or out and also when powering in or out. A loose cable/strap may rewind improperly and cause winch damage.**

Secure the cable hook to prevent personal injury or property damage.

LOADING

1. Align the boat to trailer. Make sure that the remote is unobstructed by the trailer frame or other objects.

⚠ WARNING

Always stand clear of the area between the boat and winch. Serious injury could occur if the cable breaks.

2. Free-spool the winch cable out (or power out with control) and attach the cable hook to the eye on the boat.

3. The clutch control knob must be tight to winch the boat

4. Press and hold the retrieve button to begin retrieving the boat.

5. Power in the cable IN until the boat touches the bow stop. Secure boat to trailer with tie-downs once the boat is fully loaded.

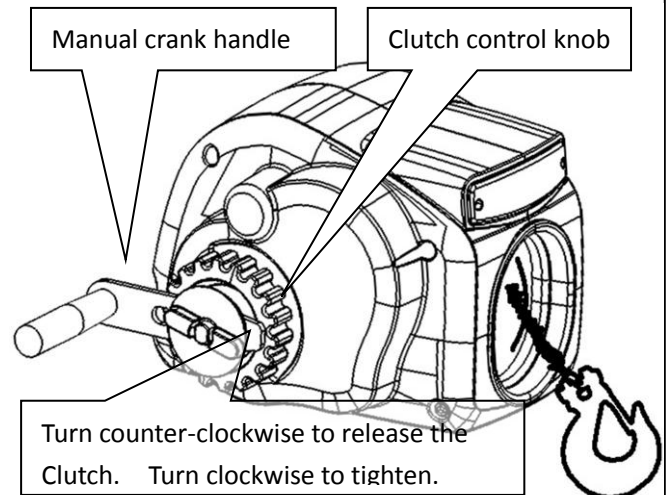

⚠ DANGER

Do not use the winch to solely hold the weight of the boat while in transit. Always secure the boat to the trailer with tie-down straps before towing the boat and trailer.

6. Make sure clutch knob and boat-to-trailer straps are tight and secure.

MANUAL CRANKING

You may manually crank the winch to retrieve a boat.

1. Remove the crank handle from the housing.
 2. Remove the outer wing nut, loosen the clutch knob, and place the hand crank on the shaft. Tighten wing nut against crank handle (leave the clutch knob loosened).

3. Turn crank handle clockwise to retrieve boat.

4. After using the emergency hand crank, remove it and replace in rear of housing.

5. Replace wing nut and tighten.

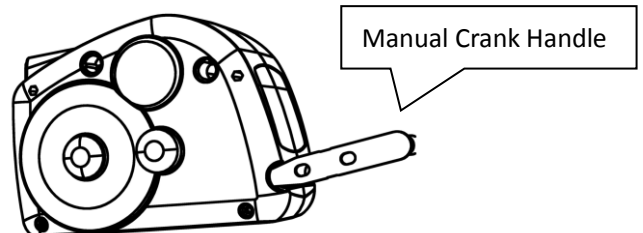

Maintenance

LUBRICATION

The cable should be lubricated a minimum of once a year with a Wire Rope Spray, WD40 or a similar product. Spray the shaft and the cable as the cable is being wound. You may remove the cover and lubricate the gears once a year with marine grease. Be careful not to get grease on the clutch lining. Before removing the housings, slice the printed label down the middle with a utility knife.

SALT WATER RINSING

To minimize common corrosion from salt water, it is a best practice to rinse off the winch after each use with fresh water. Simply point a hose inside the rope opening, over the cover and around the surrounding boat deck to wash away any salt water residue.

CABLE REPLACEMENT

⚠ DANGER

Always unplug the wiring harness to prevent accidental starting before attempting to install, service, or perform any maintenance. To replace the cable, follow the outlined procedures. Use an exact replacement TRAC cable. The winch rating and cable strength are carefully matched.

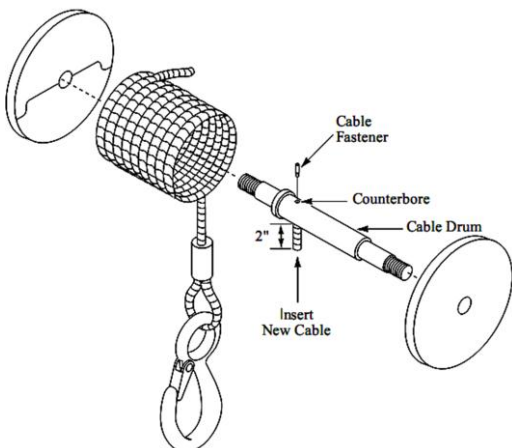

1. Unplug the power cord. Loosen the clutch knob and free-spool the cable out.
2. It is not necessary to remove the cover in order to replace the cable; however, removing the cover does create more access to the drum shaft and make the installation easier.



3. Remove the set-screw on the cable spool and remove cable.
4. Insert the new cable into the drum shaft hole and replace set-screw and tighten.
5. Reassemble the cover halves back onto the winch if they were removed during the cable installation process.
6. Power-in the cable with a light load to help wind the cable straight and tight onto the drum.

COURTESY LIGHT OPERATION

The trailer winches come equipped with a 12-volt Courtesy light. The light can be used when the winch is running or when it is idle. The winch must be wired to a 12-volt battery in order for the light to function. There is a push button switch located on the wired and wireless controls of the winch that activates the light.

Push the button  to turn light on and press the  to turn it off.

⚠ WARNING

To prevent damage to light, do not operate light for longer than 20 minutes.

LIGHT BULB REPLACEMENT

1. Remove the two screws that hold the Lens against the winch cover
2. Remove the lens.
3. Remove the bulb.
4. Replace with new light bulb and reinstall lens. The light bulb is a 5W halogen bulb. Higher wattage may melt the housing and void warranty.

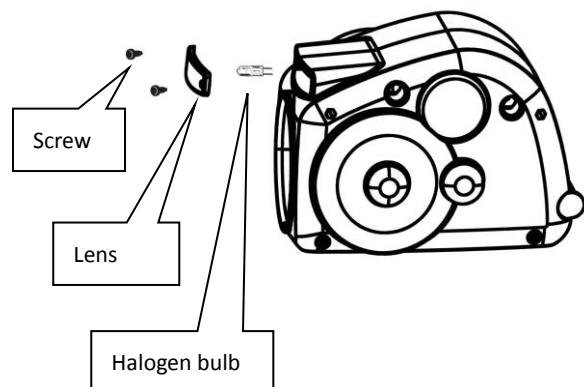

Troubleshooting Guide

Symptom	Possible Causes	Corrective Action
Winch does not operate.	<ol style="list-style-type: none"> 1. Disconnected power wire. 2. Disconnected control wire. 3. Damaged Circuit Breaker. 	<ol style="list-style-type: none"> 1. Start by checking the wiring at the battery. Bypass the circuit breaker and test the winch. If the winch operates, replace the circuit breaker. 2. Check wiring insulation for worn or bare spots that may be causing a short. 3. Check all connections for tightness.
Load slips under retrieval.	<ol style="list-style-type: none"> 1. Clutch knob not fully tightened. 2. Clutch lining worn or dirty 	<ol style="list-style-type: none"> 1. Tighten clutch knob. 2. Replace clutch lining or clutch knob.
Transmitter will not operate winch but manual override switch will.	<ol style="list-style-type: none"> 1. Transmitter was not programmed properly to the receiver. 2. Battery in transmitter is low or dead. 3. The transmitter is outside of its recommended operating radius. 4. The transmitter is not properly oriented to the winch. 5. Transmitter or receiver is bad. 	<ol style="list-style-type: none"> 1. Program or reprogram wireless remote according to the instruction manual. 2. Replace the battery. 3. Get closer to the winch, recommended operating range is 10-15 feet from center of the winch. 4. Position the remote above the level of the winch. 5. Contact service center to replace wireless remote.
Light will not turn on	<ol style="list-style-type: none"> 1. Winch is not connected to 12-volt battery. 2. Bulb is burned out. 3. Bulb is loose in the retaining clips or there is a loose connection. 	<ol style="list-style-type: none"> 1. Wire winch to 12-volt battery using the supplied wiring harness. 2. Replace bulb with new one. 3. Attached bulb so that it is secure within the bulb socket.

FREQUENTLY ASKED QUESTIONS

- Q:** Can I mount the winch on an angle? **A:** Yes, the winch can be installed at up to 15 degree angle (tilted up or down), but not much more than that or the cable will rub on the winch housing. **NOTE:** The winch should be installed so the cable/strap (as it exits the winch) is even with the bow eye on the boat when the boat is in the fully loaded position on the trailer. If the winch is too high, extra stress is exerted on the boat's bow eye and rear of the trailer. If the winch is too low, it will pull the boat into the bunks instead of along them. To achieve equal height of the winch and bow eye, raise or lower the winch stand or reposition the winch.
- Q:** How close can I mount the winch to the bow eye? **A:** We recommend eight (8) inches clearance between the winch and bow eye to prevent the cable/strap hook from being drawn into the winch drum. There is such a wide variation between trailer and boat types, that you may need more clearance, or less might be acceptable. Consider your application and position the winch so the hook remains outside the winch housing. If necessary, relocate the winch stand or bow stop to obtain clearance.
- Q:** What is the best way to power the winch? **A:** There are three ways to power the winch:

 1. The best way is to use the vehicle's battery. The tow vehicle's engine (alternator/generator) puts out about 17 volts and plenty of current (amps) to power the winch. This allows the winch to achieve maximum pulling power. To use the vehicle's battery, a vehicle wiring kit (Item T10135) can be used to route the power from the vehicle's battery to the rear of the vehicle where a plug system can be used. The winch power cable can be plugged into this system.
 2. A deep cycle marine battery can be placed in the rear bed of a pick-up truck and the winch connected to it. Use good judgment to secure the battery while trailering.
 3. A deep cycle marine battery can be installed on the trailer tongue. Be sure to use an adequate battery box and means to secure the battery during trailering.

- **Q:** Can I use the trailer light plug on my tow vehicle? **A:** The older style “4-FLAT” plug (four electrical connections in a straight row) cannot be used. The winch draws too much current for these light-weight wires. The new style 7-point round connectors typically have a 30 amp circuit. The trailer winches can draw up to a maximum of about 35 amps. So, if the winch is “maxed out” it would cause the circuit breaker to break the circuit. If the boat was light, or trailer had rollers, it is possible the winch would not reach 30 amps. There are so many variables such a ramp angle, boat weight, resistance on the trailer bunk/roller, etc., that we do not know if your rig would work or not. Many of our customers are successful using this circuit, but we do not know if your boat and trailer would work or not. Wiring your vehicle with a high-current 60 amp circuit is best. However, if you want to try the 30 amp circuit in your round plug on your tow vehicle, it is up to you. To use this circuit you would need to ground the winch’s negative (black) wire to the trailer frame. The positive wire would be connected to the 30 amp circuit on your round plug on your vehicle. A round plug adaptor can be purchased (we do not sell them, check any store that sells trailer lights) to plug into the receptacle on your vehicle. The receptacle on your vehicle plug does NOT have a high-current ground (black wire), so the trailer and vehicle frame must complete the ground circuit, while the positive wire does run through the round plug.
- **Q:** Where does the circuit breaker go? **A:** The circuit breaker gets attached to the positive (+) battery post. Never attach the circuit breaker to battery negative. If for some reason, the circuit breaker cannot be placed at the battery post, it can be spaced up to 6” away from the post, by adding a short length of battery wire between the post and the breaker.
- **Q:** Why don’t you include the vehicle wiring? **A:** We are trying to keep winch costs low and not everyone requires the vehicle wiring. A kit is available from TRAC (Item T10135), visit our website, TRAC-Outdoor.com, for details.
- **Q:** What size/gauge wire should I use to wire my vehicle? **A:** As a minimum, 10-gauge wire is acceptable. 8-gauge is best.
- **Q:** How much current (amps) does my winch use? **A:** It depends on the weight of your boat, if you have roller or flat bunks on trailer, angle of boat ramps, etc. The rough range is 20 to 35 amps.
- **Q:** Can I place a strap on my cable winch? **A:** No, the spool is too wide and there is no good way to attach the strap to a cable drum. We do make the Lite Cruiser with strap - Item T10129.
- **Q:** Do I need to lubricate the winch? **A:** The cable should be lubricated a minimum of once a year with a Wire Rope Spray, WD40 or a similar product. Spray the spool and the cable as the cable is being wound. You may remove the cover and lubricate the gears once a year with marine grease. Be careful not to get grease on the clutch lining. It is not necessary to lubricate the internal gears on a new winch.
- **Q:** Should it be this loud? **A:** It’s an electric winch with steel gears and normally has gear noise. It’s normal.
- **Q:** Can I winch the boat in manually if I don’t have electric power? **A:** Yes, the manual crank comes with the winch and can be used to winch the boat onto the trailer.



Limited Warranty

This limited warranty is provided by TRAC Outdoor Products Co (TRAC) to the original consumer purchaser (purchaser) of the new (not refurbished) TRAC Trailer Winch. This limited warranty is not transferable to any other party. TRAC will at its option repair or replace any part of the TRAC Trailer Winch which may be found by TRAC to be defective within two (2) years of original purchase. TRAC does not pay for the shipping cost from original purchaser to TRAC. You will have to ship the items to us for repair or replacement. For warranty repair or replacement, the purchaser will provide dated proof of purchase (sales receipt) and promptly notify TRAC of the request for warranty action. The purchaser will notify TRAC by email at info@TRAC-Outdoor.com or by calling 615-641-2542 for warranty action. Purchasers will be provided a Return Goods Authorization (RGA) to include with return for warranty work which will be shipped at the purchaser's expense to the address provided. The purchaser must use reasonable care in maintenance and operation of the product in accordance with this manual. Failure to follow the instructions in the manual will void the warranty. This warranty covers defects in material or workmanship of the TRAC Trailer Winch only. This warranty does not cover failure that results from misuse, improper installation, accident, abuse, neglect, modification, or improper maintenance. There are no other express or implied warranties. Any damage to watercraft or trailer resulting from proper or improper use of this TRAC Trailer Winch is not covered under this warranty. Costs of installation or repair by service centers or marine repair facilities are not covered by this warranty. This is the exclusive remedy and any liability for any and all incidental or consequential damages or expenses whatsoever is excluded. Some states do not allow limitations on how long an implied warranty lasts, or do not allow exclusion or limitation of incidental or consequential damages, the above limitations may not apply to you. This limited warranty gives you specific legal rights, and you may also have other rights which vary from state to state.

If ordering a part, provide the product model as well as the part number.

PART NUMBER	DESCRIPTION	QTY	PART NUMBER	DESCRIPTION	QTY
1	BOLT, LOCK WASHER AND FLAT WASHER	2	29	WASHER	1
2	GRAY KNOB	1	30	BEARING WITH DEEP GROOVE	2
3	WING NUT	1	31	CLIP	2
4	BOLT, LOCK WASHER AND FLAT WASHER	2	32	LONG SHAFT	1
5	LEFT PLASTIC COVER	1	33	PLATE	2
6	SPLIT PIN	1	34	FRICTION PLATE	2
7	WASHER	1	35	FRICTION GEAR	1
8	DUPLEX GEAR	1	36	NUT	1
9	DUPLEX GEAR SHAFT	1	37	LOCK WASHER	1
10	LOCK WASHER	1	38	WASHER	1
11	NUT	1	39	SPOOL GEAR	1
12	BOLT, LOCK WASHER AND FLAT WASHER	3	40	WASHER	4
13	SHAFT	1	41	CLIP	2
14	TIGHTENED PAD	1	42	BEARING WITH DEEP GROOVE	2
15	SPLIT PIN	1	43	WASHER	1
16	FRAME	1	44	SPOOL SHAFT	1
17	CONTROL BOX	1	45	PLATE	1
18	SELF-TAPPING SCREW	1	46	STEEL ROPE	1
19	MOTOR	1	47	HOOK	1
20	HANDLE	1	48	PLATE	1
21	RIGHT PLASTIC COVER	1	49	HOLDING SCREW	1
22	NUT	2	50	LED COVER	1
23	RUBBER COVER	1	51	BULB	1
24	RUBBER COVER	1	52	SELF-TAPPING SCREW	2
25	BOLT, LOCK WASHER AND FLAT WASHER	2	53	LIGHT LENS	1
26	NUT	1	54	SELF-TAPPING SCREW	2
27	LOCK WASHER	1	55	PLASTIC LOOP	1
28	HEXAGON GEAR	1			

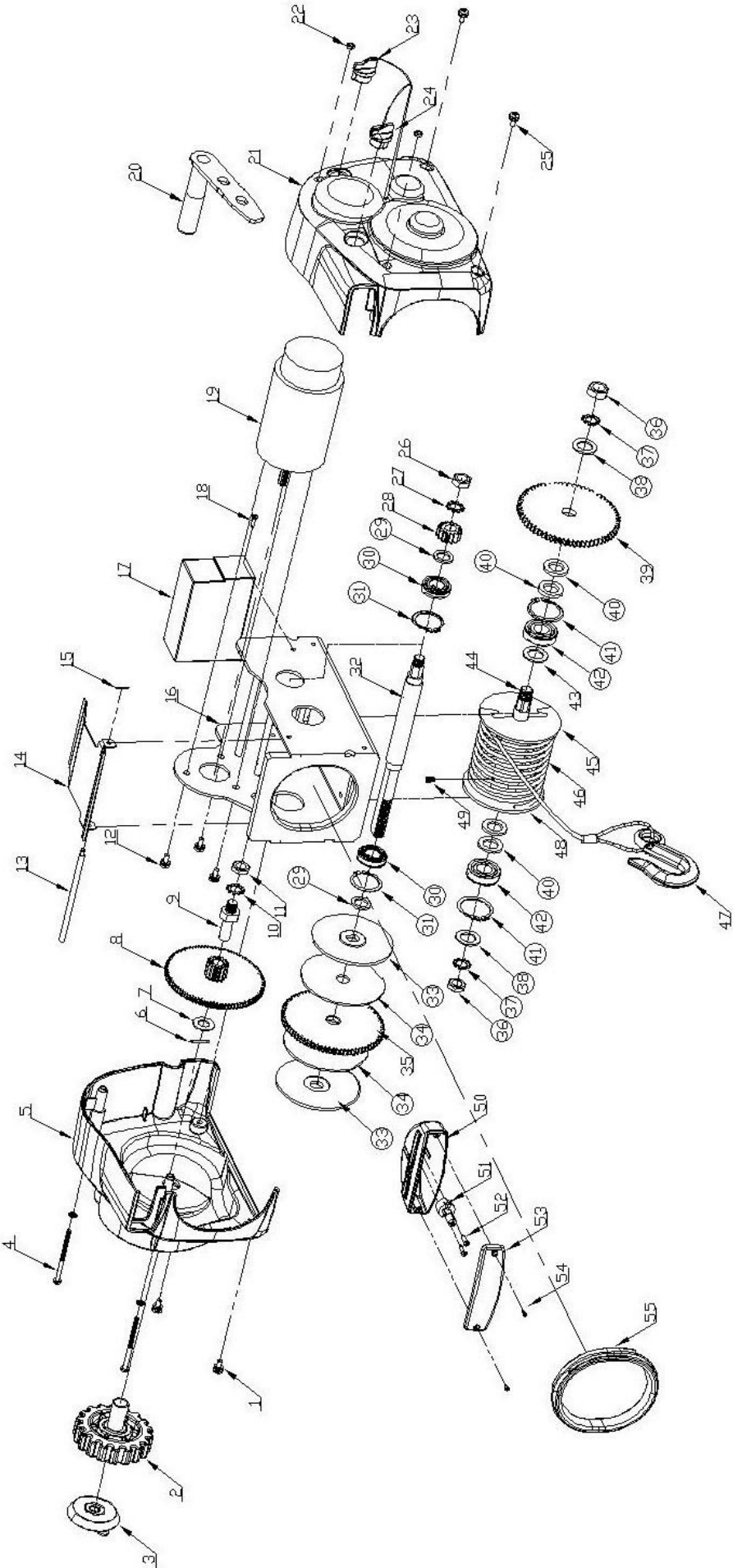

TRAC Outdoor Products Company
6039 Dana Way
Antioch, TN 37013
www.trac-outdoor.com
info@trac-outdoor.com
615/641-2542