

LOAD CONTROLLER II

ON-BOARD COMPRESSOR CONTROL SYSTEM



MN-337
(10508)
ECR 5279

P/N 25812 – 5 p.s.i. Low Pressure Sensor

This part of the installation should be done after the air spring kit is installed. If you have any questions, please call our technical service number: 1-800-248-0892, ext 2.

P/N 25810 has been superceded by P/N 25812.

If you are adding this control system to an Air Lift SuperDuty application, then no modifications to the Low Pressure Sensor are necessary. If you are adding this control system to an AirLift 1000 or RideControl application, and if your specific application requires a minimum of 10 p.s.i., then it will be necessary to adjust the Low Pressure Sensor to 10 p.s.i. To increase the pressure in the Low Pressure Sensor, remove the rubber plug with pliers (Figure 2). Using an allen wrench, turn the screw clockwise 4 1/4 turns (Figure 3). Push rubber plug back into the top of the Low Pressure Sensor. Proceed with the step by step installation instructions.

Do not cut, trim, modify, or disassemble the harness. If you have excess length, simply coil it up and secure out of the way with the provided tie straps. All preassembled gauge panels have been 100% leak & function tested. DO NOT attempt to tighten, loosen, or adjust any fittings or connections. This will likely cause a leak or malfunction and void the warranty.

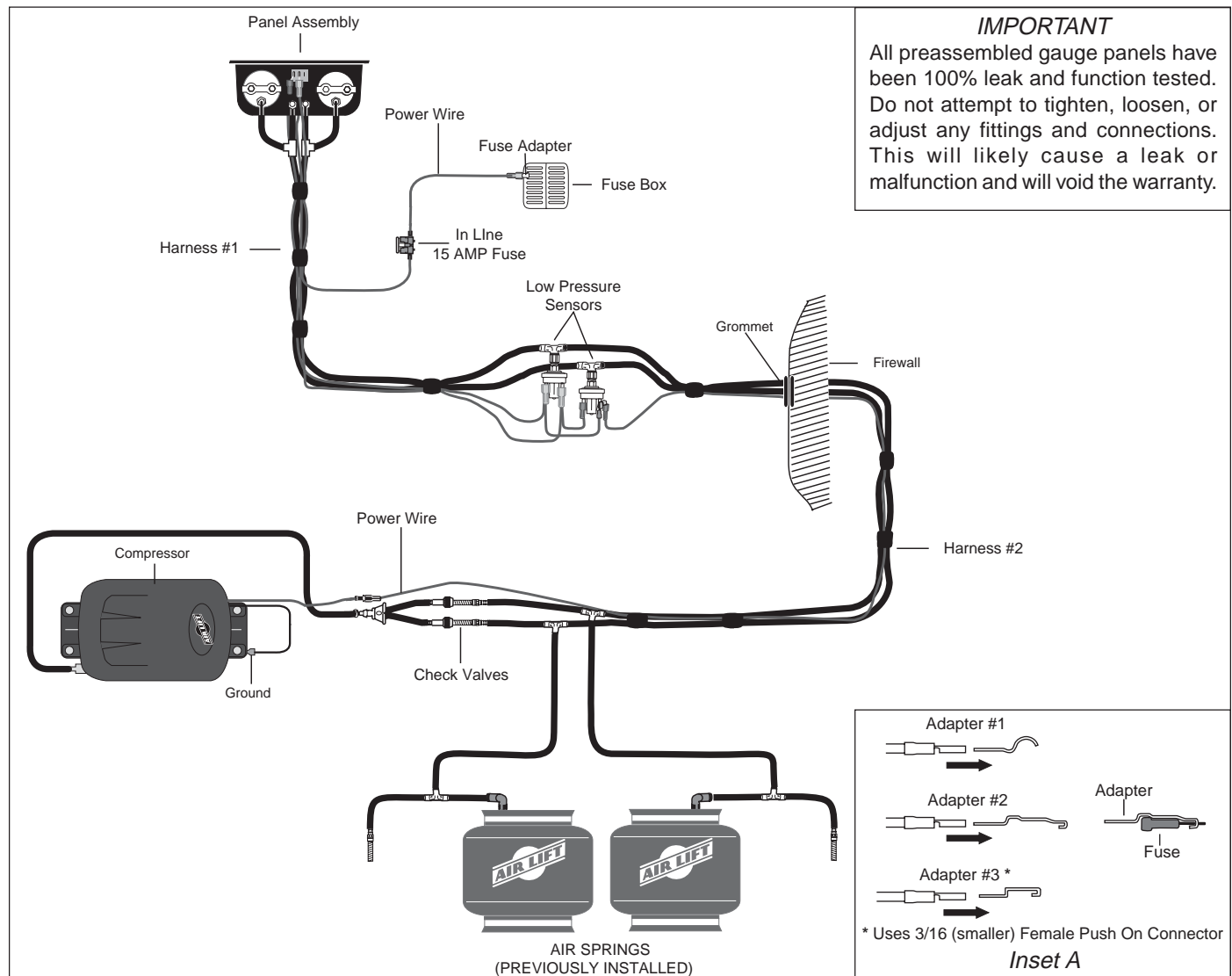

Figure 1

Step by Step Installation (refer to pages 1, 3 and 4 for line drawings):

All of the electrical connections are matched by male-to-female push-in terminals. All of the air line connections will be white-to-white, no tape-to-no tape, indicated by the color band. The color band also serves as a reference point for installing the air line into the fitting. Properly installed, the front edge of the color band should be against the collar of the fitting (Figures 4 & 6).

We recommend that you install the air spring kit first per the instructions provided with the air spring kit.

1. Install the gauge panel. Select a convenient mounting location that has a sturdy rigid surface. The bottom edge of the dash on either side of the steering wheel is a good location. Attach the panel to the selected location with the black self-tapping screws.
2. Now install the compressor unit. Hold the compressor in the recommended location and use the provided silver self tapping screws to attach the mounting brackets to the vehicle. In some cases the mounting area does not provide enough room to use a drill to drive the screws in. It may be necessary to use the mounting brackets as a template to drill $\frac{13}{64}$ " holes through the frame first and then use a $\frac{7}{16}$ " nut driver to install the self tapping screws. *NOTE: Attach the ground wire to one of the screws (Figure 1).*

For Box Frames: In some cases the frame section will not be wide enough to mount the compressor legs flat to the rail. Refer to Figure 7 in this situation.

CAUTION: Do not drill any holes into the frame or the floor board before checking for hydraulic lines, gas lines, and/or electrical wires that may need to be moved aside. Also, when attaching to the floor board, it is important to check where the screws protrude through the floor board. It may be necessary to trim or cover the top of the screws inside the vehicle. A sealer should be used around the screw to prevent the elements from entering the cab area.

3. Now connect Wiring Harness #1 to the back of the gauge panel. With your thumb against the front side of the switch, connect the wire by pushing the female connectors onto the blade connectors on the switch. Match the air line by the color band on the air line to the color band on the tees. Push the air lines onto the "T" fittings until the air line completely covers the barb (Figure 4). Lubricating the air line will ease pushing the air line over the barb. Do not connect the power wire at this time.

Wiring Harness #1 also connects the gauge panel to the Low Pressure Sensor assemblies. The Low Pressure Sensors protect the air springs from failure resulting from low pressure in the unloaded condition. These sensors are preset to maintain a *minimum* pressure of 5 psi in the air springs. The sensors measure the pressure in each spring and turn on the compressor if the pressure falls below 5 psi. *NOTE: The Low Pressure Sensors are preassembled onto Wiring Harness #1. The sensors should be located under the dash inside the vehicle and secured with the provided tie straps.*

4. Push the air line coming from the "Y" assembly onto the barb fitting on the compressor. Make sure the air line covers all barbs. A small amount of water or lubricant and pushing with a slight circular motion will ease installation.

Connect the check valves and power wire on Harness #2 to the "Y" assembly as shown in Figure 5. *Do not overtighten the check valve connector. Hand tight is sufficient.*

Route Wiring Harness #2 from the compressor. Use existing grommets in the floorboard or firewall to route the Harness from the compressor to the Low Pressure Sensors on Harness #1. In some cases, a hole may have to be drilled to allow access for the Harness. Drill a 1" diameter hole and install the provided grommet (Figure 8). It will be necessary to seal any grommets or holes that have been cut, drilled or removed so as not to allow elements to enter the cab area of the vehicle.

When routing Wiring Harness #2 from the compressor, it should *not* be routed so as to lay on, or near, the exhaust pipe/muffler/catalytic convertor of the vehicle. Routing along the top of a crossmember or over a heat shield is recommended.

5. Now connect Wiring Harness #2 to Wiring Harness #1 inside the vehicle. Simply connect the red wire from Harness #2 and the banded and no tape air lines to the Low Pressure Sensors. See Figure 6 for air line and electrical connection.
6. The next connection is between each air spring and the air line "T" fitting located just ahead of the check valves in Harness #2 (Figure 1 & 5). With the air springs deflated, use a hose cutter or razor blade to cut the air line already installed between the air springs and the inflation valves. Install the provided "T" fittings (Figure 1) by pushing the air line into each leg of the "T" until you feel a definite "click". Each line should go in $\frac{9}{16}$ ". Connect a single length of air line to the open leg of each "T". Bring each of the lines to the "T" fittings in Harness #2 just in front of the check valves and connect as shown in Figure 5. Route the air line across the chassis from the far side over the exhaust system heat shields and along the frame up to the compressor. Avoid heat sources, sharp edges, and tight bends.

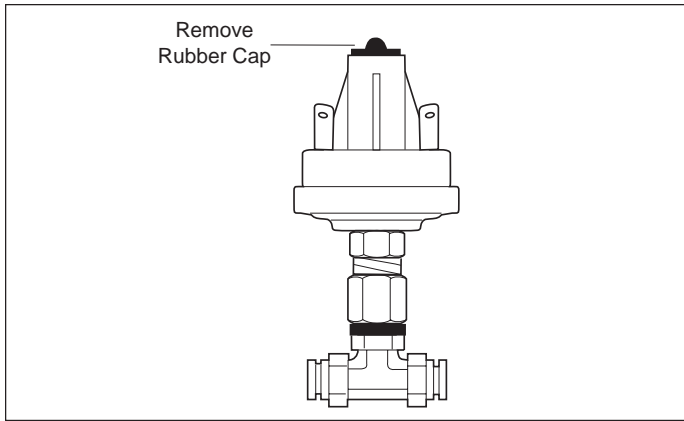

Figure 2

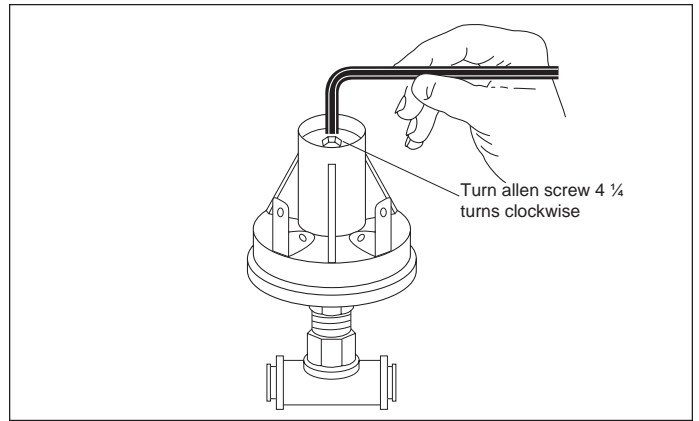

Figure 3

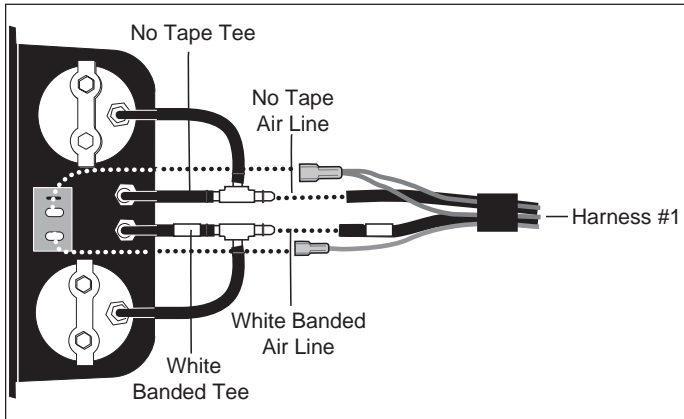

Figure 4

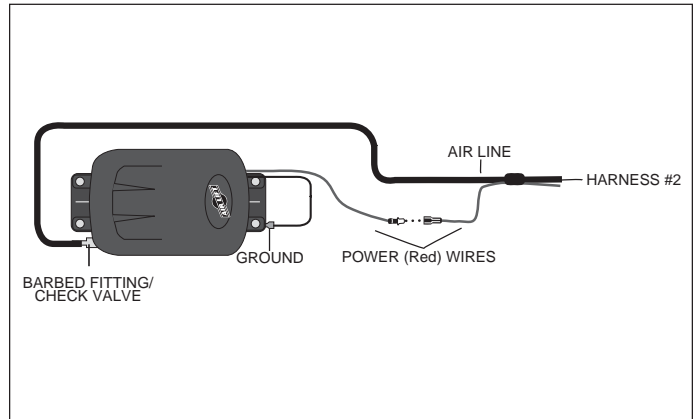

Figure 5

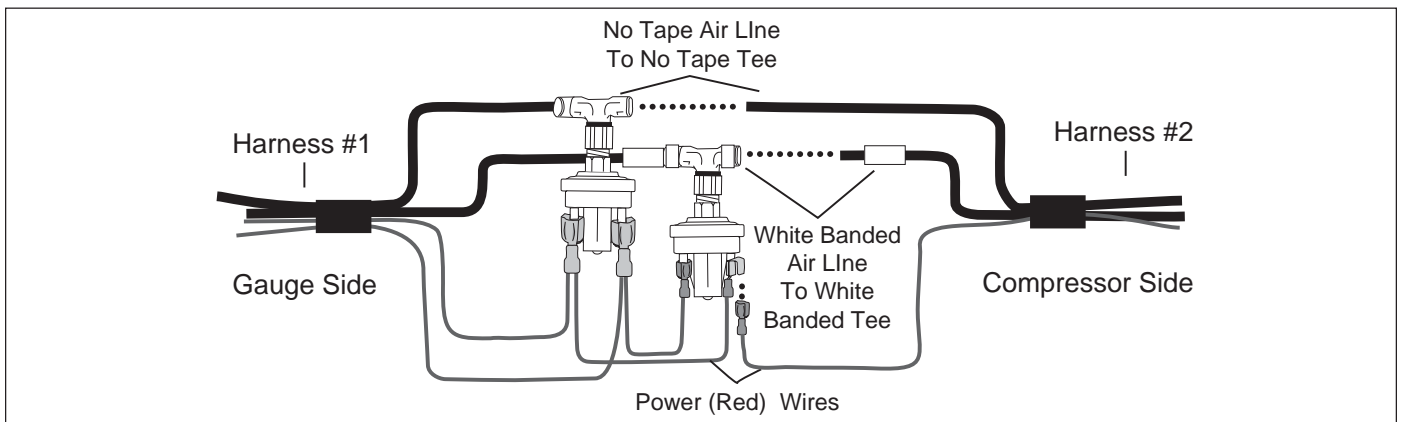

Figure 6

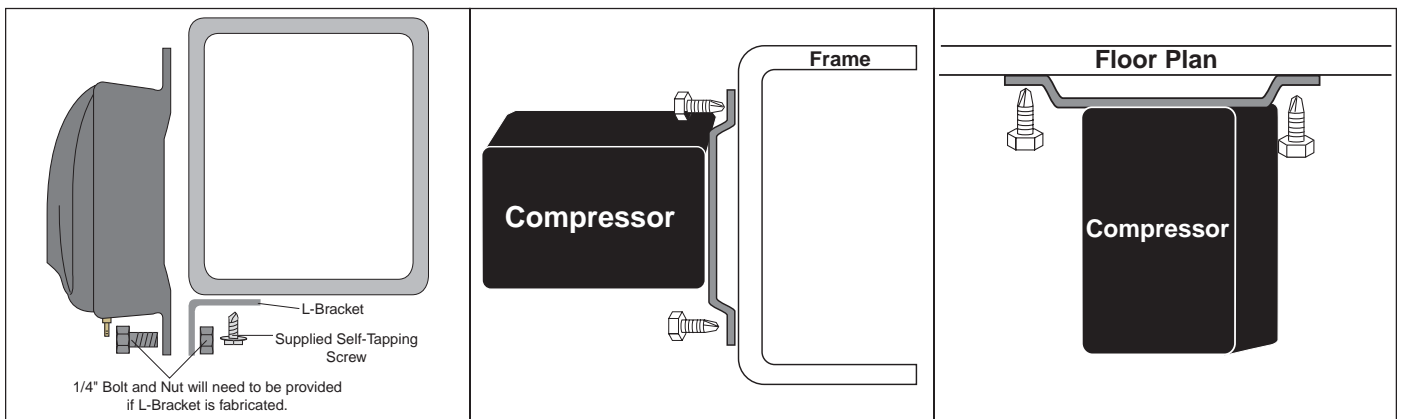

Figure 7

You will find the flexible grommet in the sealed parts package.

After the hole is drilled (see the instruction manual for correct hole size) and before you route the harness through the firewall, simply insert the grommet and "walk" the material around the inside edge of the drilled hole. You may have to trim it to get an exact fit.

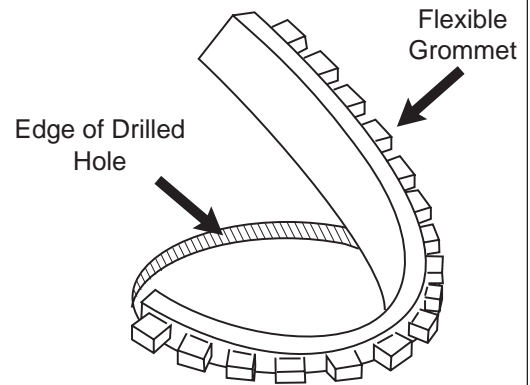

Figure 8

7. Now connect the power wire from Harness #1. Route it to the vehicle fuse box. Use a test light to determine which open terminal (accessory, etc.) works only when the key is in the "on" or accessory position (or refer to the owners manual for an available accessory fuse). The terminal should have an amperage rating equal to or higher than the 15 amp in-line fuse. Connection to the fuse terminal will depend on what type of fuse your vehicle uses. If your vehicle uses the barrel type fuse, use adapter #1. If you have the standard spade type fuses, use adapter #2. Many late model vehicles use a smaller spade type fuse which requires adapter #3 (see Inset A on the front page). If adapter #1 or #2 are used, it will be necessary to cut off the 1/4" female connector attached to the power wire and crimp the smaller 3/16" female connector supplied with this kit. *NOTE: Connect adapter to "HOT" side of the fuse (use a test light to determine). With the ignition on, the compressor will turn on and fill the system to 10 p.s.i. before shutting off.*
8. GAUGE LIGHT: Attach a 1/4" female connector to both the red and black wires. Plug the wires into the 1/4" male terminals on the back of the gauge light. Route the red wire for the illuminated gauge to harness number one's fused wire or to a dash light wire circuit and attach with the quick splice provided. Ground the black wire to an adequate ground. Use the additional wire and connectors supplied if longer leads are needed (Figure 1).
9. Press the off/on button to inflate both air springs and use the small deflate button to adjust the pressure. Inflate to 30 p.s.i. (20 p.s.i. for AirLift 1000 kits). Check all fittings and inflation valve cores with a solution of 1/5 dish soap to 4/5 water in a spray bottle for leaks.
10. Recheck air pressure after 24 hours. A 2-4 p.s.i. loss after initial installation is normal. If pressure has dropped more than 5 p.s.i., re-test for leaks with soapy water solution. Please read and follow the Maintenance and Operating tips in the installation manual that came with your air spring kit.

IMPORTANT: If the compressor runs continually or often, then there is a leak. Disconnect the compressor at the fuse box and test for leaks with a soapy water solution.

CAUTION: Never run the compressor longer than four minutes continuously. Allow at least five minutes for cool down before starting the compressor again.



Thank you for purchasing Air Lift Products

Mailing Address:
AIR LIFT COMPANY
P.O. Box 80167
Lansing, MI 48908-0167

Street Address:
AIR LIFT COMPANY
2727 Snow Rd.
Lansing, MI 48917

Local Phone: (517) 322-2144
Fax: (517) 322-0240

For Technical Assistance call 1-800-248-0892

"The Choice of the Professional Installer"

Printed in the USA