



4330 S. Johnson Rd. - Chanute, KS 66720  
800-837-8578  
info@popuphitch.com

## Installation Instructions

# PopUp Model 139 Toyota Tundra (include crew max)

Fits 2007 - 2016 2WD & 4WD  
Long and Short Beds



[www.popuphitch.com](http://www.popuphitch.com)

FOR THE SAFEST INSTALLATION

11/15

**WARNING** Most pick up trucks have **FUEL LINES** and/or **BRAKE LINES** and/or **ELECTRICAL WIRING** positioned along the truck framereils where your under-bed hitch will install. **BEFORE INSTALLATION** identify and examine the location of fuel lines, brake lines and electrical wires. Be sure you will not damage fuel lines, brake lines or electrical wiring when positioning the hitch components, drilling holes or tightening fasteners. **Be Certain To Avoid Fuel Tanks When Drilling Holes.**

- Wear Safety Glasses, Gloves and Particle Mask for protection while installing a under-bed gooseneck hitch.
- ALWAYS correctly chock tires prior to raising truck with jacking device. For protection ALWAYS use jack stands when working under or around a truck which has been raised by a jacking device.
- Be certain the exhaust system is cool prior to installation to avoid possible burns from hot tail pipe and muffler.
- Torque ALL fasteners used in the under-bed gooseneck hitch installation as specified in these Installation Instructions.
- **READ ALL SAFETY AND WARNINGS ON THE LAST PAGE OF THE PROVIDED INSTRUCTIONS.**

## INSTALLATION PROCEDURE

**WARNING: Verify adequate trailer swing clearance between trailer nose and cab of truck, and trailer and rear of truck. READ spray in bed liner warning on last page.**

1. Mark and center punch a location from the rear lip of the truck bed (tailgate end) centered between the wheel wells as stated below: **All Models 42 3/4"** Center a hole in this location using a **3" hole saw**. Smooth the hole with a file and clean all saw tailings from the bed area before proceeding.
2. If using a vehicle hoist, raise the truck at this time. If using a jacking device always chock the front tires to prevent the truck from rolling. Jacking against the rear bumper or frame, lift the rear of the truck approximately 10". **It is not necessary to lift the rear tires off the ground.** Properly position jack stands under the rear frame of the truck to protect against jack failure.
3. **Identify the Front and Rear Crossmembers.** The Front Crossmember has the end holes closer to the end of the bar.
4. Slide the Crossmembers across the frame with the notches facing forward on the Front Crossmember and rearward on the Rear Crossmember. The Chamfered area of the notch is to be down. Use an adjustable wrench to turn the Crossmember to an upright position. You may have to trim the bed sealant some to do this.
5. Raise the Center Assembly into position with the ball socket toward the front of the truck. Use an overhead lifting device, or a saw horse in the bed of the truck, and cable or strap to hold the Center Assembly firmly against the underside of the bed floor.
6. Fasten the Center Assembly to the Cross Members using 1 1/4" x 1/2" bolts and flat washers.. **Draw the Center Section against the bars but do not tighten at this time.** Square the Assembly across the frame.
7. Fasten the frame plates to the Cross Bars with 1 1/4" x 1/2" bolts and flat washers **do not tighten at this time.** Fasten the Side Plates to the frame using the 4 1/2" U-Bolts. **Tighten the top and bottom nuts on the U-Bolts evenly. DO NOT over tighten the top nuts.**
8. **CAUTION:** Avoid fuel tank, brake lines and/or wiring.

## INSTALLATION PROCEDURE- CONTINUED

9. Torque 1/2" fasteners to **torque specifications** in the following sequence: **First** the Cross Members to Center Assembly, **then** the Cross Members to the Frame Plates.
10. Drill four 1/2" holes for the Safety Chain Brackets from under the truck bed. Place a U-bolt in each pair of holes from the top side of the bed. From under the bed place a spring and 1/2" nut on each U-bolt leg. **Tighten each nut until threads are flush with bottom of the nut.**
11. From the driver side, pass the Actuating Rod through the hole between the Frame Plate extensions and into the linkage coupler. Align the Actuating Rod so the set screw seats in the hole provided in the rod and tighten to **torque specifications**. Be certain the Actuating Rod moves in and out freely.
12. The final step is to raise the ball and check the position of the slide from under the truck. When the ball is fully raised, the Roll Pin Stop should be against the ball tube. This allows the Detent Ball to lock the slide in place and positions the ball over the flat surface at top of the slide. In this position it is impossible for the ball to retract without manually pushing in the handle.
13. Please read the **SAFE TOWING INSTRUCTIONS** on the WARRANTY sheet. Fill out and return warranty card to us, or go online to [www.popuphitch.com](http://www.popuphitch.com) and fill out the online version.

### Torque Specifications:

1/2" grade 8 bolts - 119 ft. lbs.  
Actuating rod set screw - 15 ft. lbs.

### Hardware Provided

12 - 1/2" X 1-1/4" Grd. 8 Bolts  
12 - 1/2" Lock Nuts  
12 - 1/2" Flat Washers  
4 - 4 1/2" U-Bolts  
2 - U-Bolts w/springs and nuts

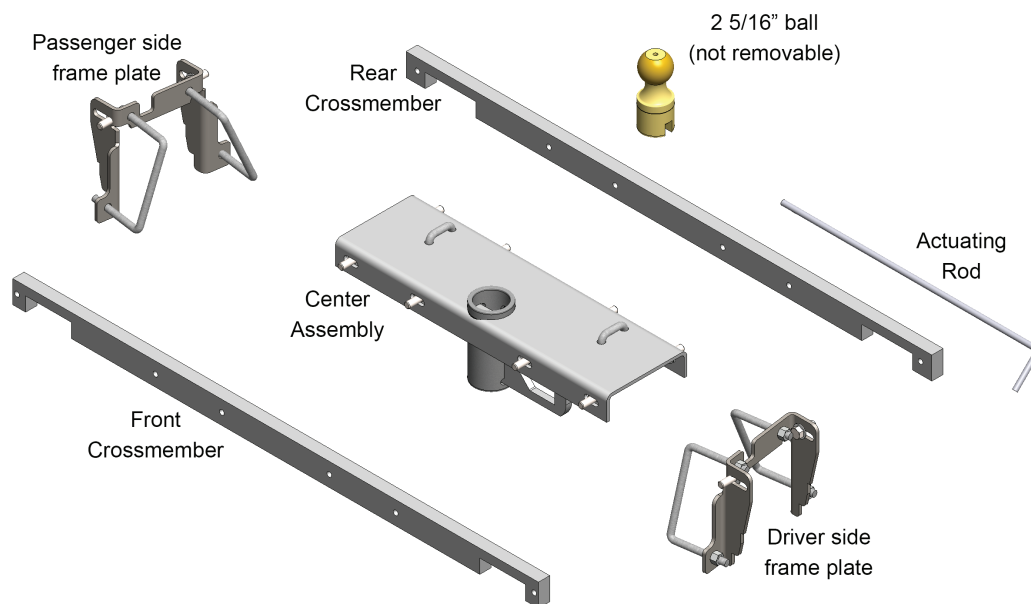

Please call or email with questions.  
Call us at 800-837-8578 or  
email us at [info@popuphitch.com](mailto:info@popuphitch.com)

Model Number 139  
Gross Trailer Weight: 30M lbs.  
Gross Trailer Tongue Weight: 7.5M lbs.

# PopUp<sup>®</sup>



## READ ALL SAFETY AND WARNINGS BEFORE STARTING THE INSTALL

### WARNING AND SAFETY INFORMATION, READ ENTIRELY BEFORE INSTALLATION.

Read all installation and operating instructions along with all labels before using this product.

PopUp Towing's under-bed hitches are standard with a 2-5/16" ball. Make sure the coupler on the trailer is designed for 2-5/16" ball. Using a larger size coupler could cause loss of attachment and cause serious injury.

Do not modify this product in any manner. Doing so could alter the integrity and proper use of the product causing serious damage or injury.

Do not exceed tow or tongue rating of coupler, tow or tongue rating of the hitch, or tow or weight ratings of the truck or trailer. See vehicle and trailer manufacturer information for proper ratings. Exceeding these ratings may cause damage to truck and/or trailer, or possible bodily injury.

Adding components such as a PopUp Towing under-bed gooseneck hitch to the chassis of any vehicle can be hazardous. There is potential for unexpected combustion of fuel, electric shock, burns, shifting or falling of unstable vehicle, damage to vehicle, injury from tool usage and many other hazards. This installation must be completed by someone who is aware of the hazards involved.

Always be sure the ball is properly latched into place while in the up or down position. Before hauling heavy loads make sure that your hitch will clear the truck's differential before hauling a load.

Cab clearance can be an issue with short bed trucks and limits towing on certain trailers. Failure to insure that there is adequate clearance before towing, may result in property damage, or serious injury.

**IMPORTANT:** The hitch is designed to install only at the location described in the included instructions. Failure to place the ball hole precisely may result in property damage or difficulty during installation.

Failure to follow the bolt tightening sequence and torque settings listed above may result in the hitch being misaligned which could affect the performance of the hitch, or result in property or bodily damage.

PopUp Towing Products assumes no responsibility for injury to self, or damage that may occur during installation. As always its best to have this product installed by an experienced installer.

**CAUTION: If your truck is equipped with a spray in bed liner that covers the rear lip of the truck bed, make sure and add the thickness of the bed liner to the hole location measurement before drilling the hole.**